

Diffraction Gratings and the Hydrogen Spectrum Spring 2023

Introduction

The object of this lab is to measure the wavelengths of light emitted from the hydrogen atom with high accuracy, and then construct an electron energy level diagram to calculate the expected wavelengths of the observed spectral lines. You will be able to measure the hydrogen wavelengths within 1% of their expected values – within 0.5% if you are careful! *You will have **two weeks** to complete this experiment; collect all your data this week (up through part III), then finish your calculations next week. Before leaving today, show your instructor your calculated wavelengths; this can catch errors that will be difficult to correct next week. The precision of your measurements will factor into your grade this week!*

Experiment – **DON'T MOVE THE SPECTROMETER UNTIL YOU'VE BEEN SHOWN ITS OPERATION!**

Experiment notes: Some portions of this experiment can be performed with the lights in the lab turned on; others only with the lights off. Parts I and II can be completed with the lights on, and Part III only with the lights off. Be certain to practice reading the vernier scale (part II, step 5) with the lights on, then again with the lights off.

I. Calibrating the diffraction grating (**LIGHTS ON**):

- You will first calibrate your diffraction grating using the light from a He-Ne laser ($\lambda = 632.8 \text{ nm}$). Place the grating and its holder on a small wooden block, with the grating (label) side of the glass slide facing the laser (*Fig. 1*). Align the laser perpendicular to the wall by holding a mirror against the wall and making sure that the light beam retraces its path back to the laser. Aim the laser near the center of the grating and align the grating perpendicular to the laser beam by making sure that the $n = \pm 2$ diffracting maxima (*Fig. 2*) are located at equal distances from the central bright spot (within 0.5 cm). Mark the position of the grating with a piece of tape on the bench.

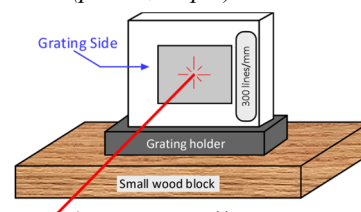

Figure 1: Grating calibration setup

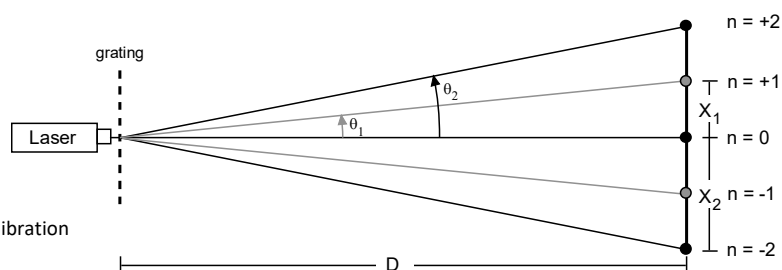

Figure 2: Grating calibration

- Use the grating equation $n\lambda = d \sin \theta$ to find d , the spacing between each slit of the grating. Use the first- ($n = 1$) and second order ($n = 2$) maxima on both sides of the zeroth-order image (*note that you can't use the small angle approximation here!*) Calculate an average value for d to 0.1 nm . **DO NOT move the grating until d is checked in the next step!**
- Ask your instructor for the actual value of d and calculate the % difference with your calculated value. *If you found a **1% or greater** difference, you should repeat your measurements and calculations!*

II. Setting up the spectrometer – *see Figures 7 and 8 on page 5* (**LIGHTS ON**):

- Turn on the hydrogen bulb and the power to the *eyepiece* of the spectrometer. When the power is turned on, you should see a bright green square (with a black cross) at the bottom of the eyepiece. You will also see a set of cross hairs above the green square: one vertical, and two horizontal. Rotate the eyepiece to focus on the crosshairs, if needed.

- Place the diffraction grating in the center (the *stage*) of your spectrometer, with the grating side facing the *collimator* (the tube with the slit at its end). At the beginning of lab, the collimator is facing the hydrogen bulb, and the *telescope* (the tube containing the eyepiece) should be parallel to the collimator. Turn the grating so that it is roughly perpendicular to the path of the beam coming through it.
- Look through the telescope. You will see a bright pink image of the tube through the slit (this is the zeroth-order image). Line the vertical cross hair up on this image; inform your instructor if the vertical crosshair is not parallel with the zeroth-order image from top to bottom.
- Gently rotate your grating clockwise or counterclockwise on the stage until a bright green cross appears in your field of view. Center the grating so that the bright green cross, the slit image, and the vertical crosshair are on top of each other (*Figure 3a*; an annotated view through the eyepiece appears in *Figure 3b*). The bright green cross does not need to be between the horizontal crosshairs; you just need to see the cross for proper alignment. This configuration ensures that the grating is perpendicular to the axis of the telescope.

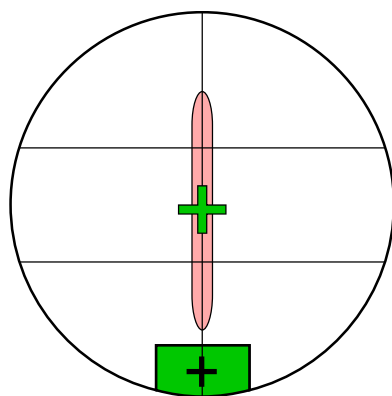

Figure 3a: The view through the eyepiece

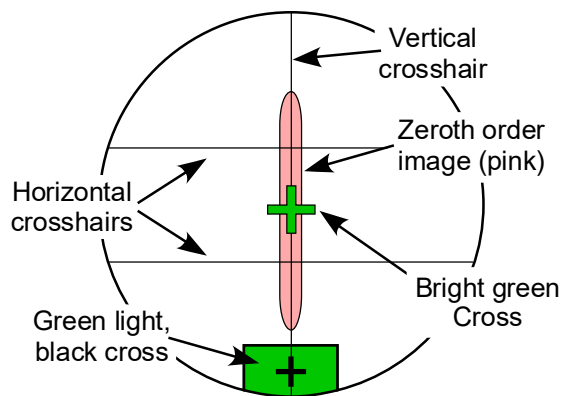

Figure 3b: Annotated eyepiece view

- Practice reading the vernier scale. The spectrometer has two verniers, on the right and left side; **be sure to use only one vernier for all your measurements.** A simplified view of the scale appears in *Figures 4* below:

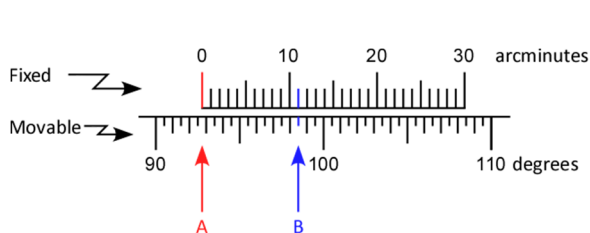

Figure 4a: Spectrometer vernier scale

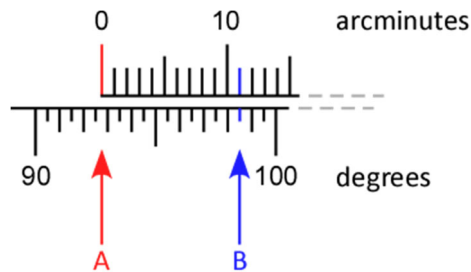

Figure 4b: Vernier scale detail

The inner (fixed) portion of the scale is marked from 0 to 30' (*arcminutes*). The outer (movable) portion is marked in half-degree (30 arcminute) increments. The vernier is read as follows:

- Note the position of the line under 0 on the fixed scale (position **A** in *Figures 4*). This gives the first digits; in the example shown, it is between $92^{\circ} 30'$ and 93° , so we will start with $92^{\circ} 30'$.
- Next, see which line on the *top* (fixed) portion matches with a line on the *bottom* (movable) scale. Read the value from the top scale; in the example, the mark under 11' (position **B**, *Figure 4b*) lines up.
- Add this reading to your first measurement: $92^{\circ} 30' + 11' = 92^{\circ} 41'$

Convert your measurement into *decimal degrees* ($1^{\circ} = 60'$) and record in your journal as the angle for the zeroth-order image. Check with your instructor that you have read the vernier scale correctly before proceeding.

III. Measuring the hydrogen wavelengths (*LIGHTS OFF*):

1. Be sure that you have recorded your measured angle for the zeroth-order image; *this measurement is important in case you need to check your measurements.*
2. Loosen the TELESCOPE LOCKING SCREW (*Figure 8 on pg. 5*). Look through the eyepiece and move the telescope to the left and right of the zeroth-order image to reveal three colored lines: violet, blue-green, and red (*Figure 5*). These are the famous *Balmer lines* of hydrogen. *There is also a fourth, very faint violet line, but it is not visible in these spectrometers.*

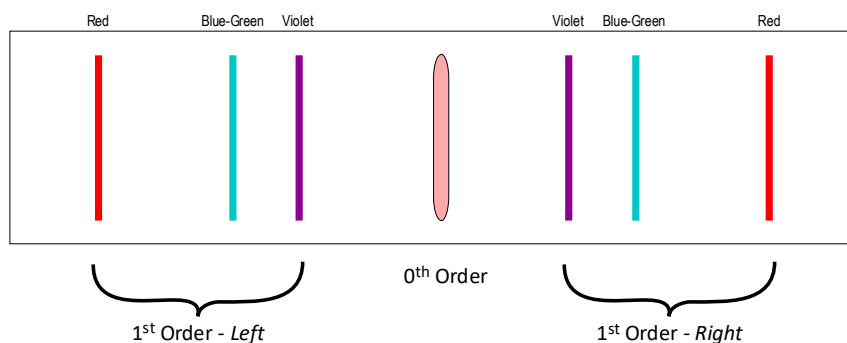

Figure 5: The view of hydrogen spectral lines through spectrometer eyepiece

3. Set up a data table in your journal with the headers shown below. The first two columns will allow you to keep track of which lab partner's measurement is recorded (*all partners in the group should read each line!*) You will record your measurement of the angle of each line in degrees and arcminutes in columns three and four. The angles will be converted to decimal degrees and recorded in columns five and six; the calculated value of θ goes in column seven. The wavelength for each partner's measurements is calculated, and then the average of all partner wavelengths are calculated for each line.

Color	Observer	$\theta_{\text{left}} (^{\circ}')$	$\theta_{\text{right}} (^{\circ}')$	$\theta_{\text{left}} (^{\circ})$	$\theta_{\text{right}} (^{\circ})$	$\theta (^{\circ})$	λ (nm)	λ_{avg} (nm)
-------	----------	------------------------------------	-------------------------------------	-----------------------------------	------------------------------------	---------------------	----------------	-----------------------------

4. Move the telescope so that the vertical crosshair is close to the violet line on the left side. *Gently* tighten the TELESCOPE LOCKING SCREW, and use the TELESCOPE FINE ADJUSTMENT KNOB to place the vertical crosshair directly on top of the violet line.
5. *Carefully* measure the angle for the violet line (θ_{left}), then repeat for the blue-green and red lines on the left side. You are trying to measure wavelengths as precisely as possible, so a *difference of more than about 3 or 4 arcminutes between you and your partner's measured angles should be rechecked!* After measuring the angles on the left side, repeat the measurements of the angles for the first-order lines on the right side.
6. After carefully measuring the angles, calculate θ for each line as follows:

$$\theta = \frac{|\theta_{\text{left}} - \theta_{\text{right}}|}{2}$$

- θ is calculated as half the angle that is swept out by measuring a line from the left to the right side. *It is therefore unnecessary to set the scale to zero when the telescope measures the zeroth-order image.*
7. Finally, calculate the wavelength (to 0.1 nm) for each hydrogen emission line using the value of d you measured in Part I.

THIS MARKS THE END OF THE FIRST WEEK'S MEASUREMENTS. YOU MUST SHOW YOUR INSTRUCTOR YOUR VALUES OF λ BEFORE LEAVING THE LAB! PLEASE TURN OFF THE SPECTROMETER, HYDROGEN BULB AND FLASHLIGHT!

IV. Determining the wavelengths and colors from the hydrogen energy levels:

The photons you have just measured have energy quanta assigned by Einstein to be:

$$E_{\text{photon}} = \frac{hc}{\lambda} \quad (1.1)$$

where $hc = 1239.8 \text{ eV}\cdot\text{nm}$. These represent the difference in the electron energy of two quantum states of the hydrogen electron.

Historically, the energies of these electron states were found to fit this empirical formula:

$$E_n = -\frac{13.61}{n^2} \quad (1.2)$$

Note that $n (= 1, 2, 3, \dots)$ in Equation 1.2 above refers to the quantum level, *not* the order of the image!

The energy is calculated in units of electron-volts (eV). This relationship can be shown with Bohr's model of the hydrogen atom and quantum mechanics.

- Use equation (1.2) to calculate the energy levels for each state ($n = 1 \dots 6$) and write them on the right side of a LARGE energy-level diagram (Figure 6).
- As an electron goes from a *higher* to a *lower* state, energy is conserved:

$$E_{\text{electron, initial}} = E_{\text{electron, final}} + E_{\text{photon}} \quad (1.3)$$

Calculate the photon energies for transitions from $n = 6, 5, 4,$ and 3 to $n = 2$ using equation (1.3). These *transitions* are represented by the arrows in Figure 6 and produce the four Balmer lines that occur at visible wavelengths (recall that you were only able to observe three of these lines due to the grating used on our spectrometers.)

- Now use equation (1.1) to calculate the wavelength (to 0.1 nm) of the photons emitted from each transition calculated above. Compare these calculated values with those measured using the spectrometer.
- Write the color of the observed line next to its transition on your energy level diagram.

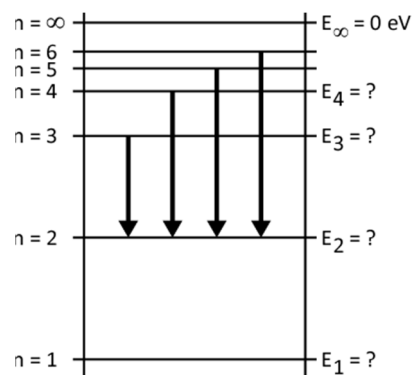
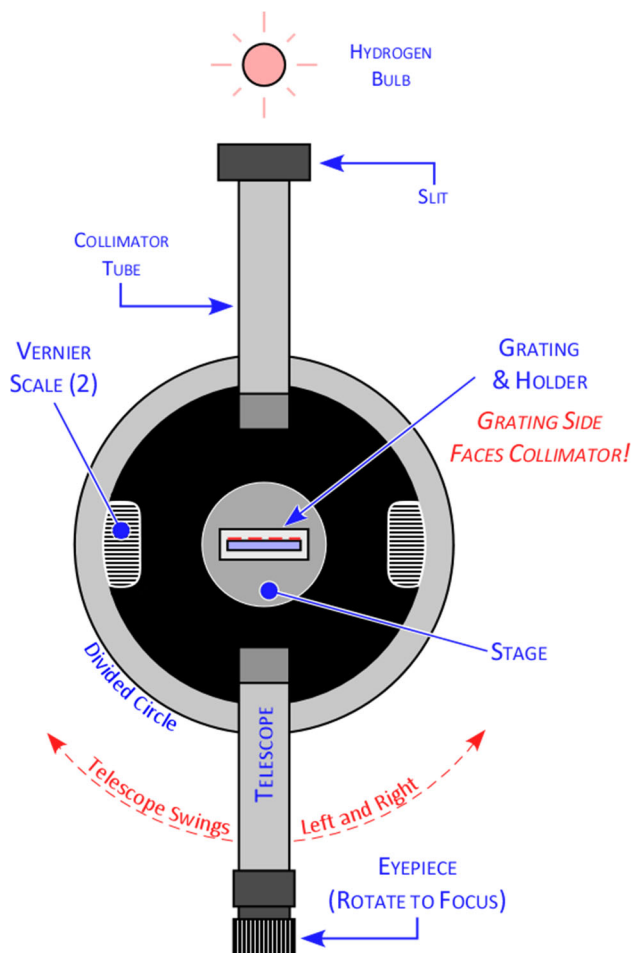

Figure 6: Energy Level diagram for hydrogen

Discussion

- Use a table to summarize your measured and expected λ 's, and their % differences.
- Discuss the agreement between the expected wavelengths (from your energy level diagram) and the measured wavelengths.
- Think about and discuss the difficulties you encountered when taking measurements.



THE SPECTROMETER, VIEWED FROM ABOVE

- Align the collimator tube and telescope as shown
- Place the grating and its holder on the stage, perpendicular to the telescope axis; *note that the label is on the grating side of the slide which faces the collimator!*
- There are 2 vernier scales – **take your reading from only 1 scale** throughout the entire experiment!

Figure 7: Top view of spectrometer

THE SPECTROMETER, VIEWED FROM BEHIND

- Loosen the *TELESCOPE LOCKING SCREW* before moving the telescope left or right. **Push only on the telescope support pillar, not the eyepiece light bulb!**
- When the vertical crosshair in the eyepiece is close to the desired spectral line, **gently** tighten the *TELESCOPE LOCKING SCREW*. Then use the *TELESCOPE FINE ADJUSTMENT KNOB* to slowly align the crosshair on the spectral line

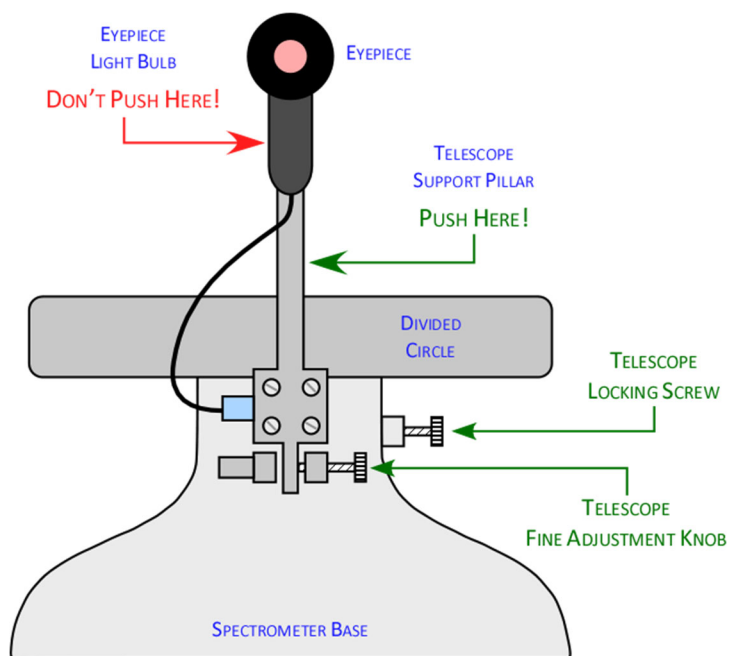

Figure 8: Rear view of spectrometer