

Exam 1

MULTIPLE CHOICE

1)⁴ How much kinetic energy will an electron need to get from point A (at a potential of +100 V) to point B (at a potential of +50 V) in the figure below?

- a) none
- b) 50 J
- c) $8.0 \times 10^{-18} \text{ J}$
- d) $2.4 \times 10^{-17} \text{ J}$
- e) $1.14 \times 10^{-27} \text{ J}$

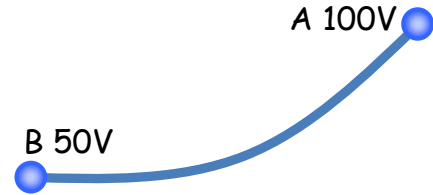

- 2)⁴ a) When resistors ($R_1 \neq R_2$) are in series, the
- i) current flowing through each is the same.
 - ii) the voltage across each is the same.
- b) When resistors ($R_3 \neq R_4$) are in parallel, the
- i) current flowing through each is the same.
 - ii) the voltage across each is the same.
- c) Capacitors 1 & 2
- i) are at the same voltage.
 - ii) have the same charge.
- d) Capacitors 3 & 4
- i) are at the same voltage.
 - ii) have the same charge.

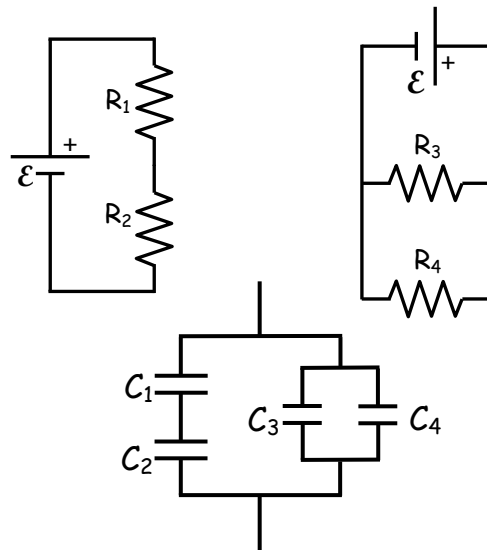

FRANK AND ERNEST

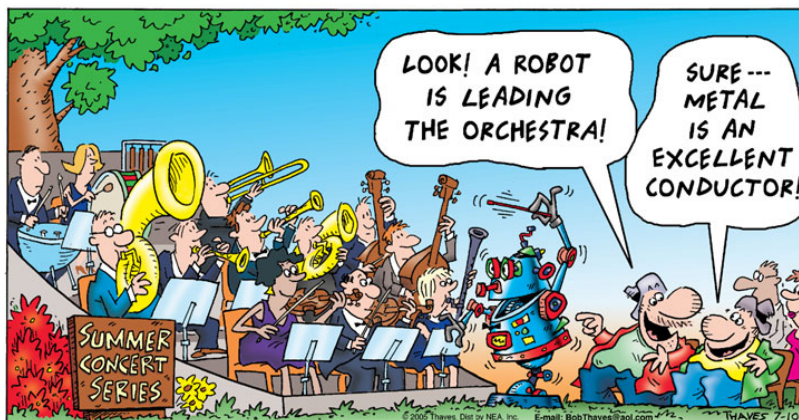

SHORT ANSWER

1)⁸ There are four graphs shown below. On each graph circle whether the device is ohmic or nonohmic (circle your choice below each graph) AND whether the resistance is increasing, decreasing or staying constant as voltage increases.

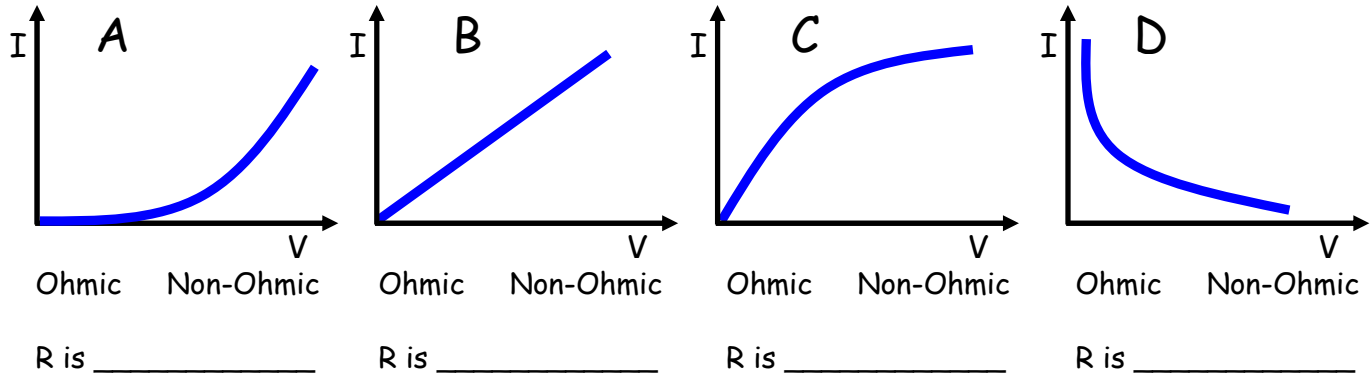

2)⁸ A capacitor is connected to a battery. What happens to the following when the distance between the plates is doubled? (circle one choice in each part).

- C , the capacitance (increases, decreases, stays the same).
- Q , the charge on the capacitor (increases, decreases, stays the same).
- V , the voltage on the capacitor (increases, decreases, stays the same).
- E , the electric field in the capacitor (increases, decreases, stays the same).

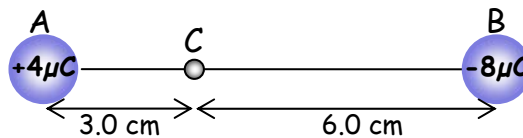

3)⁸ For charges $A = +4.0 \mu\text{C}$, $B = -8.0 \mu\text{C}$ and $C = +3.0 \mu\text{C}$ shown,

- What are the magnitude and direction of the electric force on C due to A ?
- What are the magnitude and direction of the electric force on C due to B ?
- What are the magnitude and direction of the electric force on C due to A and B ?

PROBLEMS: CHOOSE 3 OF 4.

1) For the charges $-8.00 \mu\text{C}$ at $(0.80, 0.30)$ and $+5.00 \mu\text{C}$ at $(0, 0)$ and points A at $(0, 0.30)$ and B at $(0.40, 0.80)$. Find

- a) the potential energy.
- b) the electric potential at point A.
- c) the electric potential at point B.
- d) the change in potential energy for a $2 \mu\text{C}$ charge moved from point A to point B.
- e) the work done by the electric force to move a $2 \mu\text{C}$ charge from point A to point B.

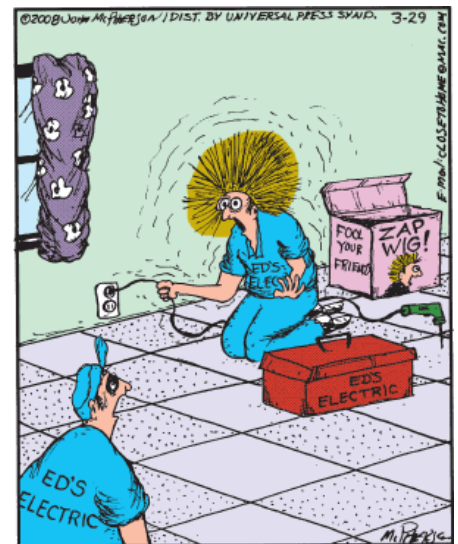
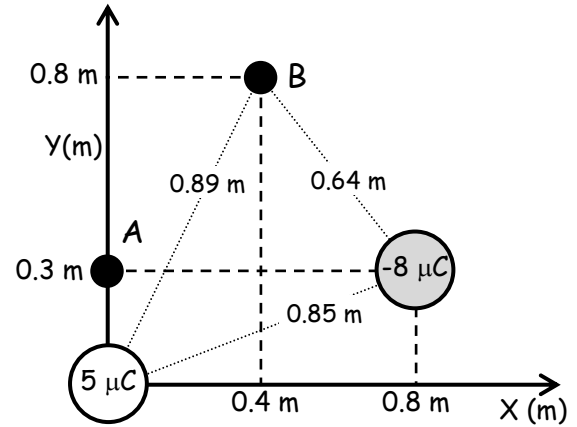

Dean liked to pull this stunt whenever he had a new partner.

2) A particle of $m = 2.0 \times 10^{-17}$ kg and $Q = +12 \mu\text{C}$ is moving in the $+x$ direction at $v = 5.0 \times 10^7$ m/s when it enters a uniform field, $E = 6.0 \times 10^4$ N/C between two charged plates that are 5.0 cm long.

- Draw an arrow indicating the direction of the E-field between the plates.
- Indicate (with + and -) the charges on the plates
- What is the magnitude of the acceleration of the particle due to the E-field?
- How long does the particle stay between the plates.
- Find the vertical deflection, d , of the particle as it leaves the plates.

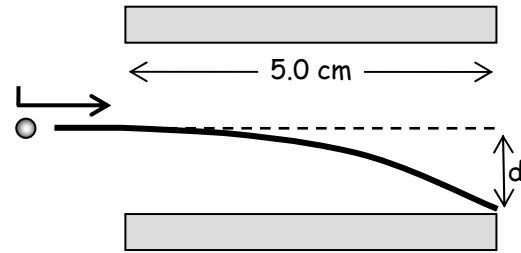

"So, Andrea tells me you two have been away recharging your batteries."

3) For the circuit shown, where $E = 20.0 \text{ V}$, $R_1 = R_2 = 12.0 \ \Omega$, $R_3 = 20.0 \ \Omega$ and $R_4 = 40.0 \ \Omega$

- a) Find the equivalent resistance for the network of resistors.
- b) Find the voltage across resistor R_3
- c) Find the current through resistor R_3
- d) Find the power dissipated across resistor R_3 .

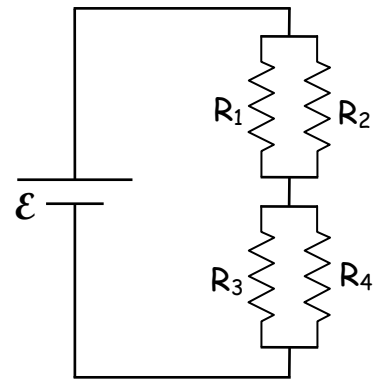

4) A heart defibrillator passes 10.0 A through a patient's torso for 5.00 ms in an attempt to restore normal beating.

- a) How much charge passed through the patient?
- b) What power was applied if 500 J of energy was dissipated?
- b) What voltage was applied?
- c) What was the path's resistance?



HERMAN[®]

by Jim Unger



11-30

© LaughingStock International Inc./dist. by United Media, 2005

"Got any 25-amp fuses?"